

Effect of Agar Jelly Coating in Rectangular Pipe to Flow Drag Reduction

Yanuar^{1†}, Gunawan¹, K. T. Waskito¹, and S. Ogata²

¹ Department of Mechanical Engineering, University of Indonesia, Jakarta 16424

² Department of Mechanical Engineering, Tokyo Metropolitan University, 1-1 Minami-Osawa, Hachioji-shi, Tokyo 192-0397, Japan

†Corresponding Author Email: yanuar@eng.ui.ac.id

(Received June 16, 2016; accepted April 12, 2017)

ABSTRACT

Drag reduction phenomena can be obtained using additive polymer that can generate turbulence damping by fluid movement and characteristic. Measurements were carried out to investigate pressure losses in square and rectangular horizontal ducts coating of additive Agar solution, with aspect ratios (e) = 1.0 and 0.5, respectively. The increment concentrations are ranged up to 2 times and drag reduction effect was obtained up to 1.5 times bigger. This research analysis was done using friction coefficients and Reynolds numbers relation to put forward drag reduction phenomena. The effect of Agar coating delayed the transition regime. The research results using 1 mm of thickness Agar coating with concentration 20% and 40% concentrations were obtained maximum drag reduction phenomena about 19% at the Reynolds number about 2,600.

Keywords: Drag reduction; Agar jelly; Coating; Rectangular pipe; Slip velocity.

NOMENCLATURE

A_c	pipe surface area	P	pipe wetted perimeter
B	coating thickness to slip velocity magnitude	Re	Reynolds number
C_w	solution concentration	u	average velocity
D_h	hydraulic diameter of rectangular pipe with agar coating wall	x	length of rectangular cross section
DR	Drag Reduction	y	height of rectangular cross section
e	aspect ratio of rectangular pipe (x/y)	γ	shear rate
f	friction factor	τ	shear stress
f_{coating}	friction factor with agar jelly coating	μ	dynamic viscosity
L	length of test pipe	ρ	density
M_n	mass of Agar powder	ΔP	pressure drop
M_w	mass of pure water		

1. INTRODUCTION

The fluid transport in pipes was economically attractive in comparison to transport by other media. Studies of drag reduction from the point of view of energy conservation have been conducted in practical fluid engineering. Recently, research on drag reduction has attracted considerable attention concerning the problem with energy conservation, which is closely related to the prevention of global warming. The methods for obtaining drag reduction are divided into two categories: passive control and active control. In the passive control of liquid flow, the most effective drag reduction method is the addition of drag-reducing additives which are high-

molecular-weight polymers. The application of drag reduction of polymers or surfactant additives is limited to closed-loop pipeline systems, since the disposal of these solutions has an adverse effect on the environment. From the point of view of environmental impact, the practical application of biopolymers is convenient because drag-reducing additives biodegrade by time. Thus, if the effect of environmental loading is considered, the application to open pipeline systems can be expected in the future. Additives such as polymers, surfactants, and fibers are well-known drag reducing agents and offer a simple means of reducing drag. Since Toms observed drag reduction with the addition of polymers in (Toms, 1949), numerous investigations

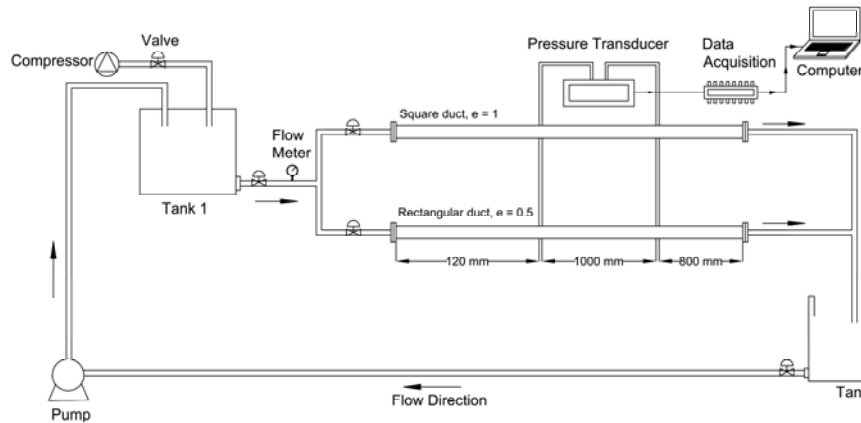

Fig. 1. Pressure drop experimental set-up.

into drag reducing agents under various conditions have been carried out. Among these, surfactants have been researched intensively due to their effectiveness and low mechanical degradation. However, as most of these additives are synthetic chemicals, they contaminate rivers and soil when solutions are drained directly, and therefore require careful disposal. Polymer has been verified in flow drag reduction by velocity profiles (Yanuar *et al.*, 2015). Although biopolymers are not subject to such disposal issues, they are not practical due to their significant mechanical degradation. On the other hand, fibers (Mih *et al.*, 1967) and (Robertson *et al.*, 1957) such as asbestos or nylon are resistant to mechanical degradation but have a disadvantage with regard to environmental load, while pulp, which is a plant-based fiber, requires high concentrations to achieve drag reduction effects. The use of fibers of the material of Nata de coco can reduce the pressure drop in turbulent flow (Ogata *et al.*, 2011). Effect of the addition of Nata de coco fiber is a very good impact. Drag reduction that obtained was 11%. The topics in laminar drag reduction using hydrophobic surface has been conducted and favorable results was obtained, such as laminar drag reduction in microchannels using ultrahydrophobic surfaces (Ou *et al.*, 2004), effective slip on textures superhydrophobic surfaces (Gogte *et al.*, 2005). Scaling laws for generic geometries (Ybert *et al.*, 2007), time dependence of effective slip on textured hydrophobic surfaces (Govardhan *et al.*, 2009), fluid drag-reducing effect and mechanism of superhydrophobic surface with micro-nano textures (Zhang *et al.*, 2014).

The Hagen-Poiseuille provides adequate solutions for flow in circular pipe. The incompressible Oldroyd eight constant fluid flow is considered between two infinite parallel plates (Siddiqui *et al.*, 2016a). In other system, like home heating, air conditioning, power plants the rectangular pipe is common use. Experimental results of rectangular duct have been reported in the past (Yanuar *et al.*, 2004) and (Zarling, 1976). Theoretical formula for stream flow in ducts of the rectangular cross-section is proposed (Cornish, 1928), and interesting results

are shown in the region at the critical Reynolds number. Mathematical expressions for the pressure distribution, velocity component, volume flux, average wall shear stress and leakage flux are presented explicitly (Siddiqui *et al.*, 2016b). This research was focused to investigate the effect of Agar solution in square and rectangular pipe for drag reduction. Agar solution was coated in square and rectangular test pipe. Agar powder is a naturally gelatinous powder derived from sea vegetables, especially in red seaweed. Suitable for a variety of thickening & stabilising applications, it is mostly used as vegetarian gelatine. It has stronger gelling effect, flavorless, odorless and colorless. Investigations were made within a range of Re from about 600 to 5×10^4 by pressure transducer. Variation of friction factors of Agar solution coating in the rectangular pipe with two variations of concentration of Agar solutions were presented in details to explain the drag reduction.

2. EXPERIMENTAL SET-UP

Figure 1 is the measurement setup. Horizontal pipe with square and rectangular cross section was used to determine flows in pipes (Rheology).

The pipe geometry effects fluid flow. The effect of different geometry causes fluid flow equations in non-circular pipe have typical rule. For non-circular duct used hydraulic diameter (D_h). For square duct, $y=x$, so, D_h obtained from equation as follows :

$$D_h = \frac{4x^2}{4x} = x \quad (1)$$

For rectangular duct D_h obtained from equation as follows :

$$D_h = \frac{4xy}{2(x+y)} = \frac{2xy}{x+y} \quad (2)$$

In this experiment D_h calculation includes Agar coating thickness. The square and rectangular duct was varied by aspect ratio (e). Aspect ratio (e) can be obtained as follows :

Table 1 Specification of Test Pipe

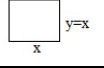
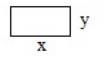
Test Pipes	Di (mm)	Do (mm)	Dh (mm)	Agar Thickness (mm)	e	Cross Section
Square	10x10	12x12	9.5	1	1	
Rect.	10x5	12x7	5.7	1	0.5	

$$e = \frac{x}{y} \tag{3}$$

This experiment used two aspect ratio, those are 1 and 0.5. The $e = 1$ means that the square duct was 10 mm x 10 mm in diameter. However, the $e = 0.5$ means that the rectangular cross section was 10 mm x 5 mm in diameter.

The bottom side of test pipe was coated by Agar solution. Agar solution is generated from mix the Agar powder and water and then boiling until the solutions made jelly. The thickness of Agar jelly solutions was 1 mm. Flow rate was varied by adjusting the valve opening and measured using flowmeter. Pressure transducer was used to measure the value of the pressure drop. The relation of shear stress with shear strain will be obtained to make the flow curve. Table 1 was the specification of test pipe. The test pipe consists of two variations as shown in the table 1 above. The cross section of square and rectangular pipe also can be shown in the table.

3. RHEOLOGICAL MODEL

The shear stress, τ is proportional to the velocity gradient, γ (shear rate), can be described by Newtonian model:

$$\tau = \mu\gamma \tag{4}$$

The Newtonian viscosity depends on the temperature and the pressure and independent to the shear rate. The viscosity is defined as the ratio of shear stress to shear rate.

The relationship shear stress and shear rate may be described by measuring the pressure drop gradient and the volumetric flow rate in rectangular pipe flow is given by:

$$\frac{D_h \Delta P}{4L} = \mu \frac{8u}{D_h} \tag{5}$$

Where: D_h is the hydraulic pipe diameter with agar coating wall, ΔP is pressure drop, L is the length of pipe (test section), and u is the average velocity.

Coefficient of friction, f , can be obtained by Darcy Equation:

$$f = \frac{2\Delta P D_h}{L \rho u^2} \tag{6}$$

Where: f is the coefficient of friction, and ρ is the fluid density. The definition of Reynolds number in rectangular pipe is given by:

$$Re = \frac{\rho u D_h}{\mu} \tag{7}$$

The Coefficient Factor in Rectangular pipe can obtain by Cornish equation (Cornish, 1928) :

$$f = \frac{64}{Re} x \left(\frac{3/2}{(1+e)^2 \left[1 - \frac{192}{\pi^5} e \sum_{n=1,3,5,\dots}^{\infty} \frac{1}{n^5} \tanh\left(\frac{n\pi}{2e}\right) \right] \right) \tag{8}$$

Drag reduction in pipe can obtain by equation:

$$DR = \left| \frac{f - f_{coating}}{f} \right| \times 100\% \tag{9}$$

DR is Drag Reduction, $f_{coating}$ is friction factor with Agar jelly coating. The solution concentration, C_w was determined based on the mass ratio of Agar powder to pure water to made Agar jelly, which is defined by:

$$C_w [\%] = \frac{M_n}{M_n + M_w} \times 100\% \tag{10}$$

M_n and M_w denote the masses of Agar powder and pure water, respectively.

4. RESULT AND DISCUSSION

Figure 2 shows the flow curves of the water in coating and without coating rectangular pipe. The wall stress τ and shear rate γ were calculated from the experimental data from laminar to turbulent flow regime. The solid line in Figure 2 indicates the value obtained by the viscosity of water in circular pipe without coating. All data of rectangular pipe both coating and without coating show linear relationship between wall stress and flow rate. It is indicated that all of them are Newtonian behaviour. The slope gradient of rectangular pipe seem lower than circular pipe, more over for rectangular pipe with Agar coating, the data seem far from the circular pipe as greater shear rate. The rectangular pipe with aspect ratio (e) = 1 was the lowest slope gradient than other data. It is indicated that in the rectangular duct with Agar coating have lower shear stress at the same shear rate value.

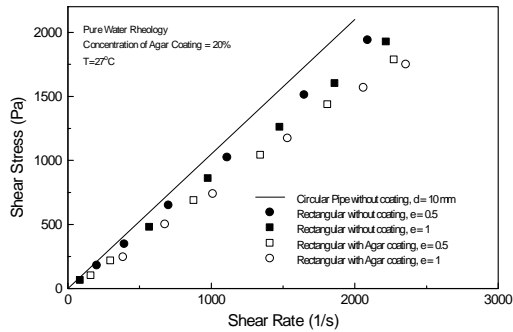

Fig. 2. Flow curve of water in coating pipe.

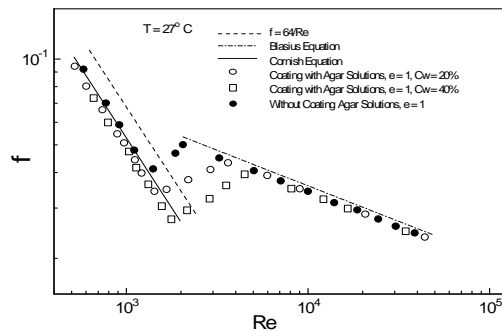

Fig. 3. Friction Coefficient versus Reynolds number in circular and rectangular pipe for $e = 1$.

Figure 3 shows the relationship between Reynolds number and friction factor coefficient based on the measured pressure drop for rectangular pipe with aspect ratio of 1 and concentration of Agar coating is 20% and 40%. The data will be compared with Hagen Poiseuille equation in laminar flow, Cornish equation for laminar flow in rectangular pipe and the Blasius equation in turbulent flow. The coefficient of friction in rectangular pipe with aspect ratio of 1 without Agar coating is lower than the coefficient of friction of water for circular pipe in laminar flow. The data fit with Cornish Equation. Coating with any suspensions did not affect to the coefficient of friction both in laminar flow and turbulent flow. However, in transition regime seems any possible reduction of friction coefficient. Furthermore, in transition regime not only have lower than friction coefficient but also occurred delay of transition. For 40% concentration of Agar coating, the data was slightly lower than 20% concentration. The effect of rectangular cross section pipe is the transition of water increases slightly. Generally for water in circular pipe, transition will be occurred in Re closed to 1500. However, this rectangular pipe shows the transition begin at $Re = 1,800$. Transition was delayed to much larger Re with Agar coating in the rectangular duct. More delayed can be occurred if the necessary precautions are taken such as minimization of duct vibration, disturbance at the inlet section, and steady flow. The transition Reynolds number for the rectangular pipe with higher concentration of Agar coating has found slightly higher than small concentration of Agar coating. In turbulent flow, the data show that coefficient of friction in rectangular pipe fits with Blasius Equation for circular pipe.

Figure 4 shows the relation between Reynolds number and friction factor coefficient based on the measured pressure drop for rectangular pipe with aspect ratio of 0.5 and concentration of Agar coating is 20% and 40%. The data will be compared with Hagen Poiseuille equation in laminar flow, Cornish equation for laminar flow in rectangular pipe and the Blasius equation in turbulent flow. The coefficient of friction in rectangular pipe with aspect ratio of 0.5 without Agar coating is lower than the coefficient of friction of water for circular pipe in laminar flow. The data fit with Cornish Equation. On the other hand, coating with Agar for 20% and 40% concentration did not effect to the friction coefficient of water. The transition was occurred in Re closed to 2,200 for 20% concentration and 2,600 for 40% concentration. The aspect ratio of rectangular pipe can affect the start of transition. Smaller aspect ratio was affected delay of transition in much Reynolds number. However in turbulent flow, the aspect ratio was slightly affected of friction coefficient.

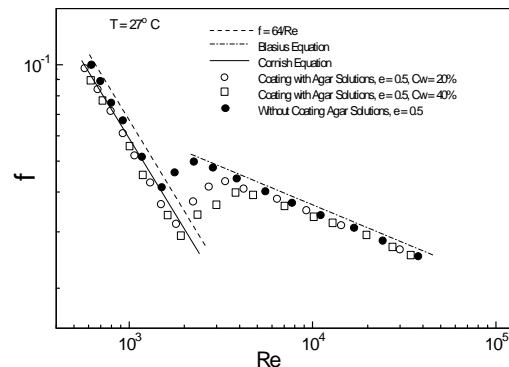

Fig. 4. Friction Coefficient versus Reynolds number in circular and rectangular pipe for $e = 0.5$.

Figure 3 and 4 also show the ratio drag reduction of coating with Agar jelly in rectangular pipe with different aspect ratio. Based on Figure, it can be seen from these results that drag reduction for a rectangular pipe with Agar jelly coating was occurred in several Reynolds number about 1,200 up to 3,500. The critical Reynolds number was delayed using rectangular pipe. The maximum drag reduction occurred at the Reynolds number about 2,600. After Reynolds number about 3,500, the data shows closed to the Blasius equation. It is indicated that did not occurred drag reduction in turbulent flow. Drag reduction of rectangular pipe with aspect ratio of 1 is greater than aspect ratio of 0.5. The reported value for rectangular pipe with aspect ratio of 1 has maximum drag reduction about 19% and in the aspect ratio of 0.5 has drag reduction 12% respectively at Reynolds number about 2,600.

Figure 5 shows the relation between pressure drop and flow rate in circular and rectangular pipe for $e = 1$. The increase in flow rate also causes increase in pressure drop, higher concentration of agar solution effects decreasing in pressure drop.

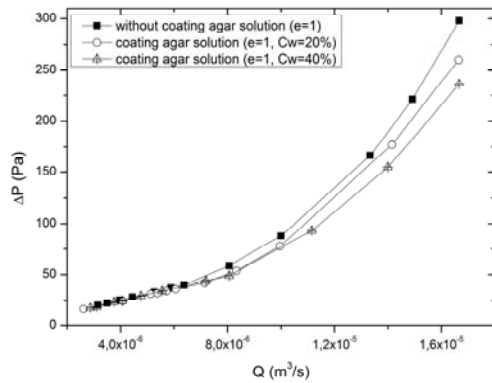

Fig. 5. Pressure drop versus flow rate in circular and rectangular pipe for $e = 1$.

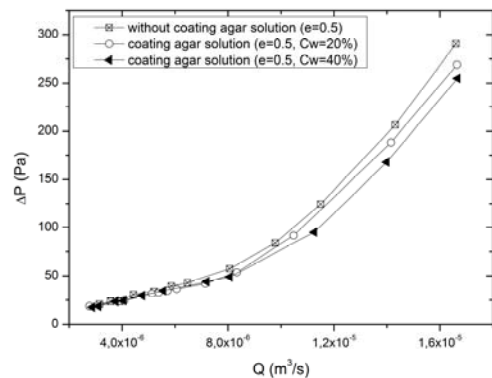

Fig. 6. Pressure drop versus flow rate in circular and rectangular pipe for $e = 0.5$.

Figure 6 shows the relation between pressure drop and flow rate in circular and rectangular pipe for $e = 0.5$. The effect of flow rate and concentration similar as $e = 1$. Yet, the ratio $e = 1$ shows slightly lower decreasing in pressure drop compared to $e = 0.5$, finally, the different aspect ratio of rectangular pipe effects in friction factor, pressure drop, and percentage of drag reduction.

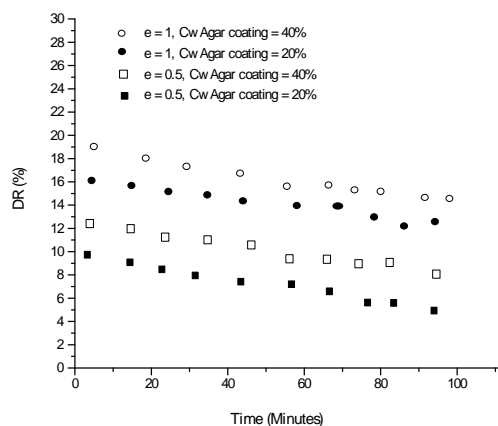

Fig. 7. Degradation Phenomena.

Figure 7 shows the degradation of Agar coating based on periode of experiment. The data shows the sama trend. After 100 minutes from initial time of experiment, the drag reduction was drop up to 15%

from 19% at the first. The degradation occurred during the test became apparent by a rise of the pressure loss. Sometimes, the apparatus could be run for approaching 100 minutes before any serious degradation occurred. The cause of this degradation was not fully understood although it is probably due to some forms of chemical action.

This study investigates the use of hydrophobicity for the engineering large slip at the fluid-solid interface. These super hydrophobic surfaces were initially inspired by the unique water-repellent properties of the lotus leaf and can be employed to produce drag reduction in both laminar and turbulent flows.

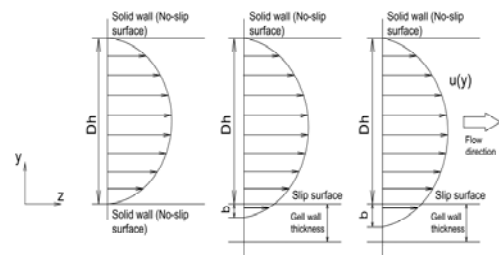

Fig. 8. Schematic diagram defining slip length and slip velocity at solid-liquid interface with agar coating.

From this experimental results obtained that drag reduction occurred at laminar and become more significant in transition regime. The drag reduction mechanism can be explained as follows, the velocity profile is present in the agar coating as shown in Figs. 8 and 9. The figures show the slip phenomena occurred at the fluid contact with gel wall that produce slip velocity caused velocity profile more advance. In the figure was illustrated, D_h is the hydraulic diameter, and b is the coating thickness related to slip velocity magnitude. Therefore, slip velocity occurred at the Agar coating surface cause drag reduction and delayed in transition.

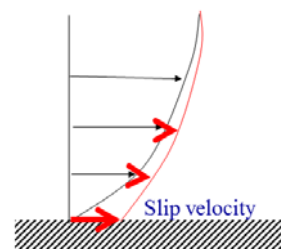

Fig. 9. Advance in slip velocity profile in the Agar coating surface.

5. CONCLUSION

The drag-reduction effect of the Agar coating in rectangular pipe was verified. The effect occurred in transition regime. With coating of Agar jelly can delayed transition. Drag reduction is significantly affected by the type of pipe and the concentration of

Agar coating. For rectangular/square pipe with aspect ratio (e) = 1, the range drag reduction is about 12% up to 19% depend on Agar concentration. For rectangular pipe with aspect ratio 0.5, the drag reduction is occurred about 6% up to 12%, respectively.

ACKNOWLEDGEMENTS

This research is supported by “Hibah Kompetensi RISTEK DIKTI 2016”, Jakarta, Indonesia.

REFERENCES

- Cornish, R. J. (1928). Flow in a Pipe of Rectangular Cross Section. *Proc. Roy. Soc. London. Ser. A*, 120. 691-700.
- Gogte, S., P. Vorobieff, R. Truesdell and A. Mammoli (2005). Effective Slip on Textured Superhydrophobic Surfaces. *Physics of Fluids*. 17, 5.
- Govardhan, R. N., G. S. Srinivas, A. Asthana and M. S. Bobji (2009). Time Dependence of Effective Slip on Textured Hydrophobic Surfaces. *Physics of Fluids* 21, 5.
- Mih, W. And J. Parker (1967). Velocity profile measurements and phenomenological description of turbulent fiber suspension pipe flow. *TAPPI* 50, 237-246.
- Ogata, S., T. Numakawa and T. Kubo (2011). Drag reduction of bacterial cellulose suspensions. *Advanced in Mechanical Engineering*. 1-6.
- Ou, J., B. Perot and J. P. Rothstein (2004). Laminar Drag Reduction in Microchannels using ultrahydrophobic surfaces. *Physics of Fluids*. 16(12), 4635-4643.
- Robertson, A. A. and S. G. Mason (1957). The characteristics of dilute fiber suspensions. *TAPPI* 40, 326-334.
- Siddiqui, A. M., A. Sohail, S. Naqvi and T. Haroon (2016b). Analysis of Stokes Flow Through Periodic Permeable Tubules. *Alexandria Engineering Journal*.
- Siddiqui, A. M., A. Sohail, A. Ashraf and Q. A. Azim (2016a). Drag Flow Analysis of Oldroyd Eight Constant Fluid. *Alexandria Engineering Journal*.
- Toms, B. A. (1949). Some observations on the flow of linear polymer solutions through straight tubes at large Reynolds numbers. *International Congress on Rheology*, Holland. 1948. Amsterdam. North I loh.aid, 11, 135-141.
- Yanuar and K. Watanabe (2004). Toms Effect of Guar Gum Additive for Crude Oil in Flow Through Square Ducts. *The 14 International Symposium on Transport Phenomena*. Bali Indonesia. Elsevier 599-603.
- Yanuar, K., T. Waskito and B. Gunawan (2015). Drag Reduction and Velocity Profiles Distribution of Crude Oil Flow in Spiral Pipes. *International Review of Mechanical Engineering* 9(1), 1-10.
- Ybert, C., C. Barentin, C. C. Bizonne, P. Joseph and L. Bocquet (2007). Achieving Large Slip with Superhydrophobic Surfaces: Scaling Laws for Generic Geometries. *Physics of Fluids*. 19, 12.
- Zarling, J. P. (1976). An Analysis of Laminar Flow and Pressure Drop in Complex Shaped Ducts. *Trans. ASME. Ser. I*. 702-706.
- Zhang, J., Z. Yao, P. Hao, H. Tian and N. Jiang (2014). Fluid Drag-Reducing Effect and Mechanism of Superhydrophobic Surface with Micro-Nano Textures. *4th Micro and Nano Flows Conference*.